

**WOMEN'S**  
**WOMEN'S SINGLE CYLINDER**  
**LB04YJ**

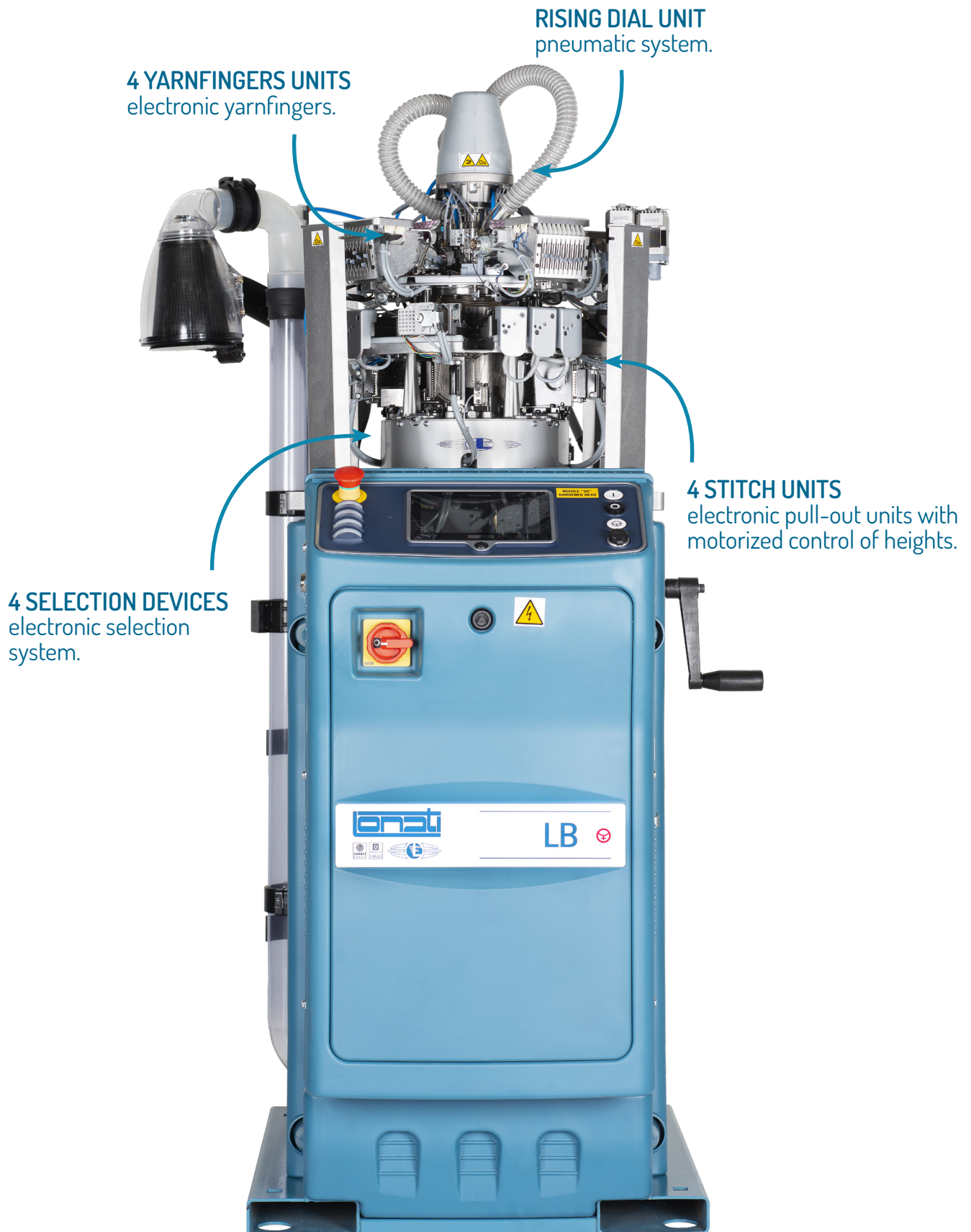

# WOMEN'S SINGLE CYLINDER

LB04YJ



**4 YARNFINGERS UNITS**  
electronic yarnfingers.

**RISING DIAL UNIT**  
pneumatic system.

**4 STITCH UNITS**  
electronic pull-out units with  
motorized control of heights.

**4 SELECTION DEVICES**  
electronic selection  
system.

**lonati** **LB**

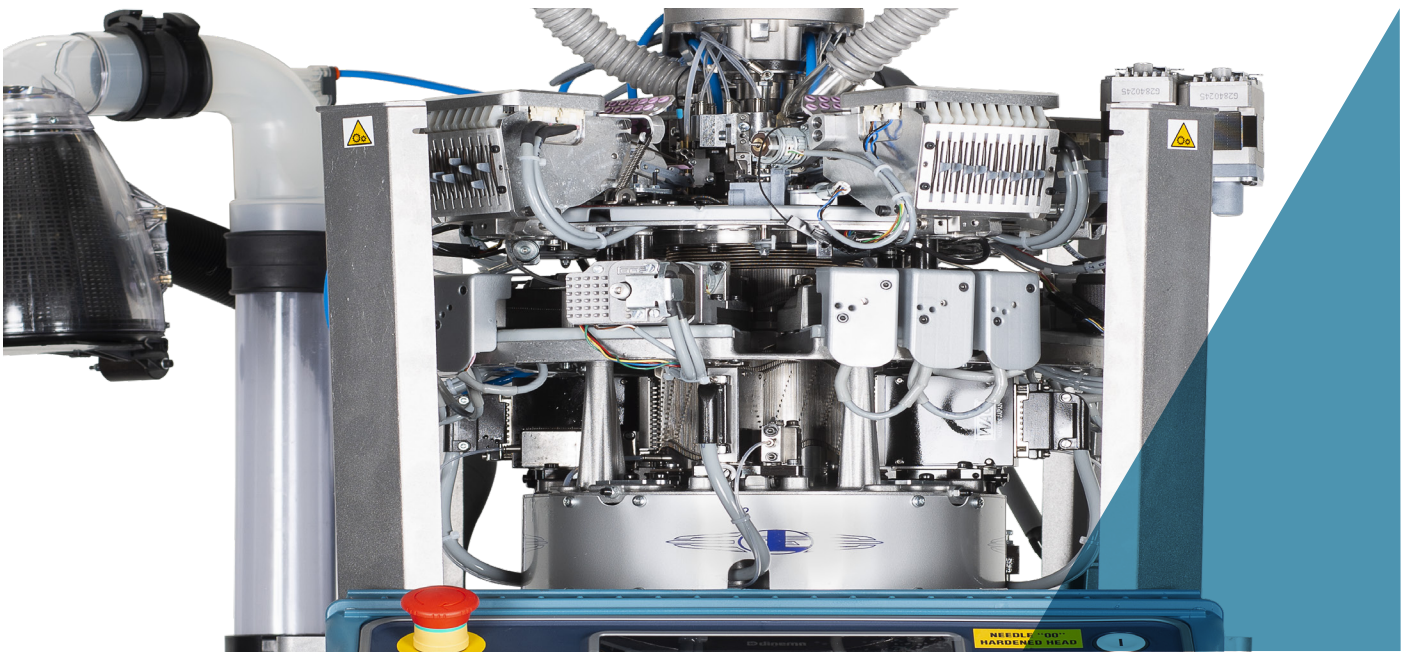

All images in this brochure are indicative and not binding.

## WOMEN'S SINGLE CYLINDER LB04YJ

Electrically controlled single-cylinder, 4-feeds machine for the production of stockings and pantyhose with 1 needle-by-needle electronic selection unit on each feed (4 in total) for the production of pantyhose in jacquard, baguette and bikini patterns. Mechanical device for laid-in on each feed. Motorized stitch cams for gradual or partial stitch narrowing or widening in any part of the sock. Stitch cams pull-out movement performed through stepper motors for pantyhose and knee-highs option with 2 colours each course, relief jacquard (cut boss). Motorized needle raising cam. Electronically controlled yarnfingers with plating positions at different heights plus 1 motorized yarnfinger for angular movement. Single or double dial jacks. Electronic device to maintain the size at any temperature of the machine.

- 4 feeds single cylinder machine
- 1 electronic selection unit on each feed
- 4 stitch units with motorized control of heights
- 4 pull-out stitch units with motorized control
- Motorized sinkers cap, 2 motors
- 30 yarnfingers
- 6 pliers suction unit

### MACHINE DIMENSIONS



Length 60 cm + yarn creel 145 cm  
Depth 60 cm + yarn creel 145 cm  
Height 136 cm + yarn creel 265 cm

### MACHINE WEIGHT



Machine 230 kg  
Yarn Creel 70 kg

### CERTIFICATION



Green  
Label

# WOMEN'S SINGLE CYLINDER

## LB04YJ

### TECHNICAL DATA

MODEL	CYLINDER DIAMETER	GAUGE	NEEDLE THICKNESS
LB04YJ(Needle latch 7 mm)	4"	32	0.34 mm

Above data are indicative and not binding.

### STANDARD DEVICES

- 40 reels yarn creel
- Sock ejection hood
- Yarn waste filter
- Stepper motor controlled suction valve
- Rotary or fixed antitwist device
- 4 mobile pull-out stitch units with motorized heights control
- 6 pliers suction unit (plates, hooks and cut-pick)
- 8 yarn sliding sensors
- Motorized radial plating on first yarnfinger on each feed
- Extra latch-opener for open-work
- Mechanical device for laid-in elastomers on each feed

### OPTIONAL DEVICES

- DREAM or DREAM ONE device for stretching socks in ejection
- 2,2 Kw suction fan
- Ethernet board for connection to Dinema Nautilus data collector system
- Dinema GRYF yarn feeder, 12 max
- Dinema Plus medical or bare elastomer yarn feeders, 4 max
- Yarn sensors, 24 max
- Motorized rising dial unit
- Mock seam device
- UPS - uninterruptible power supply

### SUITABLE YARNS

The machine is designed to be used with the following yarns

- Nylon;
- Filanca;
- Elastomers (bare, single or double cover);
- Stretch, for transparent items;

### POSSIBLE KNITTINGS

The standard machine can perform the following knittings

- Plain knit
- 1:1, 3:1, 5:1, 7:1, 1:3 fixed mesh, micromech and diagonal mesh
- Different selections for vertical cutting bands
- Several 1:1, 2:2 (cut boss) pattern, bikini pattern, pattern heel, pushup etc.
- Supp-hose on 2 or 4 feeds
- Plain knit plating on 2 or 4 feeds

# WOMEN'S SINGLE CYLINDER

## LB04YJ

### NUMBER OF COLORS

Number of colors	<ul style="list-style-type: none"> <li>-Working feeds 1-2-3-4: one color each course</li> <li>-Working feeds 1-3 or 2-4: 2 colors each course</li> <li>-Working feeds 4-1: 3 colors on feed 4 each course, 1 color on feed 1 each course</li> <li>-Working feed 4: 4 colors each course</li> </ul>
------------------	--

### PERFORMANCES

	4" CYLINDER DIAMETER
GAUGE	32
KNITTING FEATURES	550 rpm with pattern, stitch cams at 55°
	600 rpm plain knit, no pattern, stitch cams at 55°
	700 rpm plain knit, no pattern, stitch cams at 48°
	800 rpm plain knit, no pattern, stitch cams at 40°
MAXIMUM SPEED	800 RPM

Above data are indicative and not binding.

#### DISCLAIMER:

Speed may need to be adjusted according to the inclination of the stitch cams, to the mechanical parts in use and to the yarn.  
N.B. All data in the brochure are for information only and subject to change without any prior notice from Lonati SpA.

### ALLOWED PERFORMANCES

CHART OF MAXIMUM ALLOWED SPEED IN PLAIN KNIT IN RELATION TO THE INCLINATION TO THE STITCH CAMS	
Stitch cam inclination	Maximum allowed speed in plain knit
40°	800
48°	700
55°	600

NUMBER OF POSSIBLE COLORS ON EACH COURSE ACCORDING TO THE NUMBER OF WORKING FEEDS	
Working feeds	Number of colors
1° - 2° - 3° - 4°	1 each course
1° - 3° o 2° - 4°	2 each course
4° - 1°	Feed 4(3 colors) feed 1(1 color)
4°	4 each course

AVAILABLE CYLINDERS	
G675-0,34	300 - 320 - 336 - 352 - 368 - 384 - 386 - 398 - 400 - 402 - 432
G670-0,41	288 - 320 - 336 - 352
G654-0,50	176 - 208 - 240 - 256 - 288 - 320

Above data are indicative and not binding.

#### DISCLAIMER:

All data related to maximum allowed mechanical speed may require to be reduced (to be adjusted according to functional tests on the machine) when using specific particular yarns and/or knitting features.

# WOMEN'S SINGLE CYLINDER

## LB04YJ

### NOISE LEVEL

Machine average noise level, suction included LeqA = 74dBA

### LUBRICANTS

Average consumption for 500/600 dozens: 1000 gr. - Lonati recommends: Fuchs Trax 14C - Kluber Tex Sintheso M32 - Esso Eil 0287

### GREASE

For seals, bearings etc. Lonati recommends: Damping grease Nyogel 774F

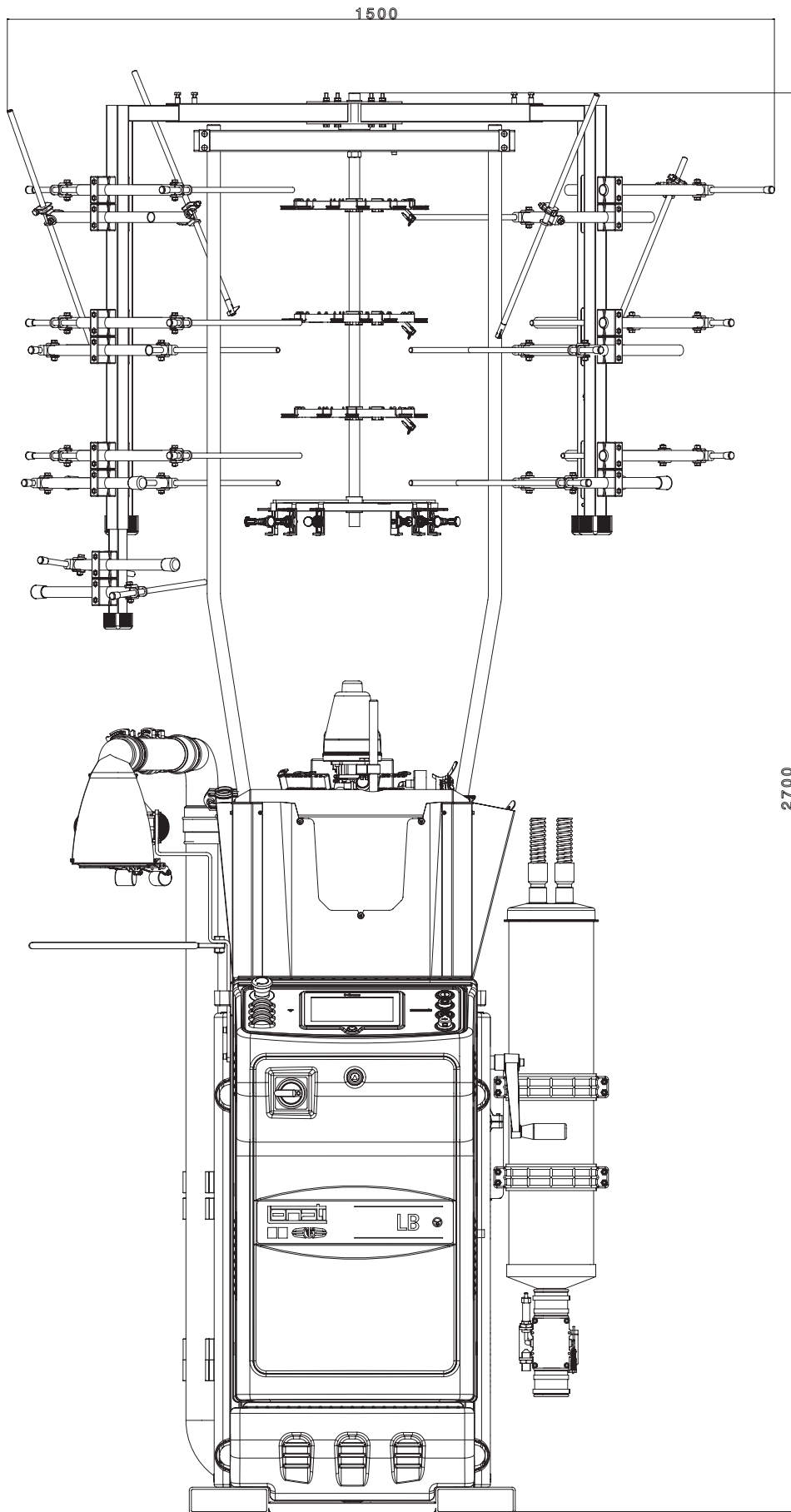

## FRONT VIEW

Machine dimensions with 26 reels yarn creel

### NOTE:

The picture may show fittings and equipment that are supplied on demand and not.



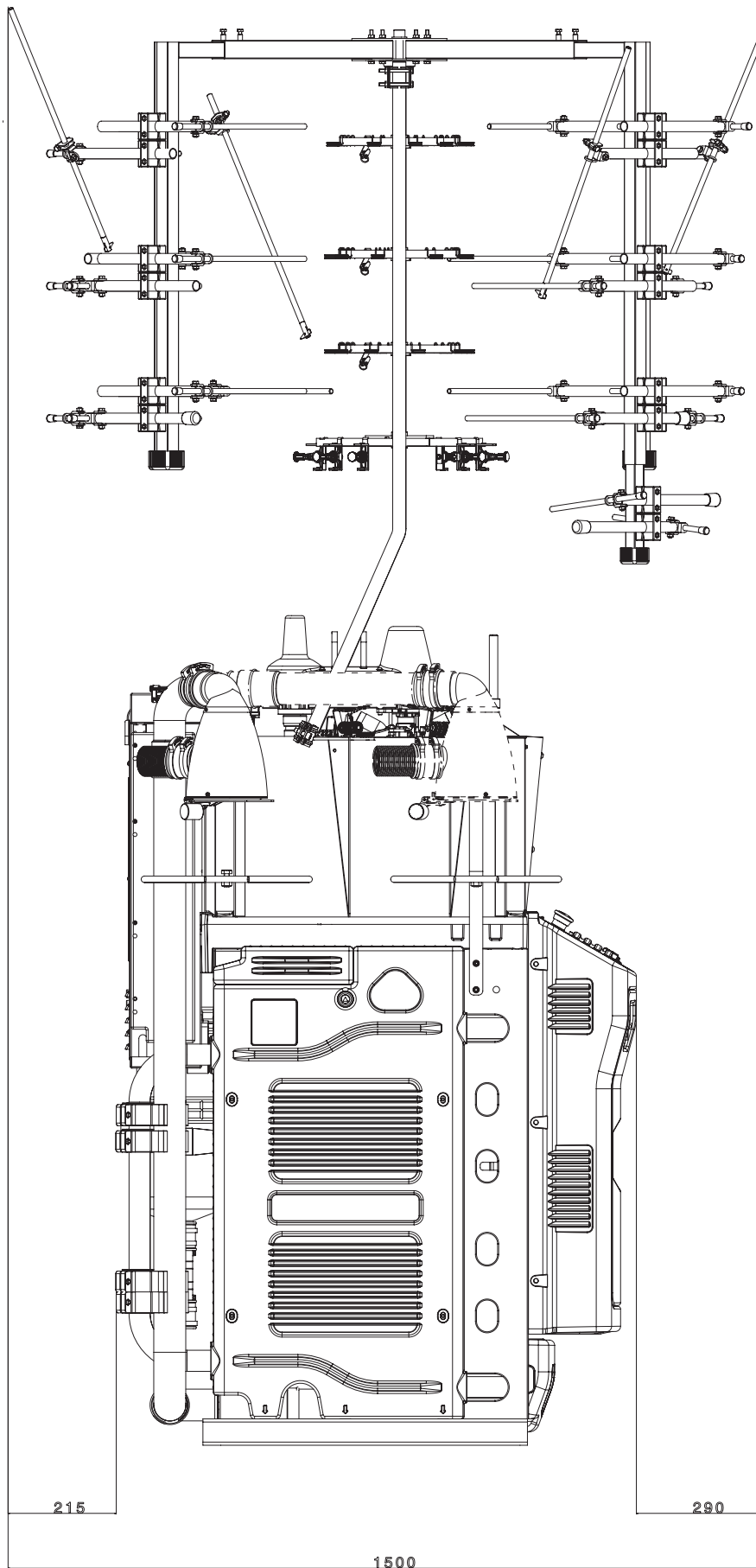

## SIDE VIEW

Machine dimensions with 26 reels yarn creel

### NOTE:

The picture may show fittings and equipment that are supplied on demand and not.

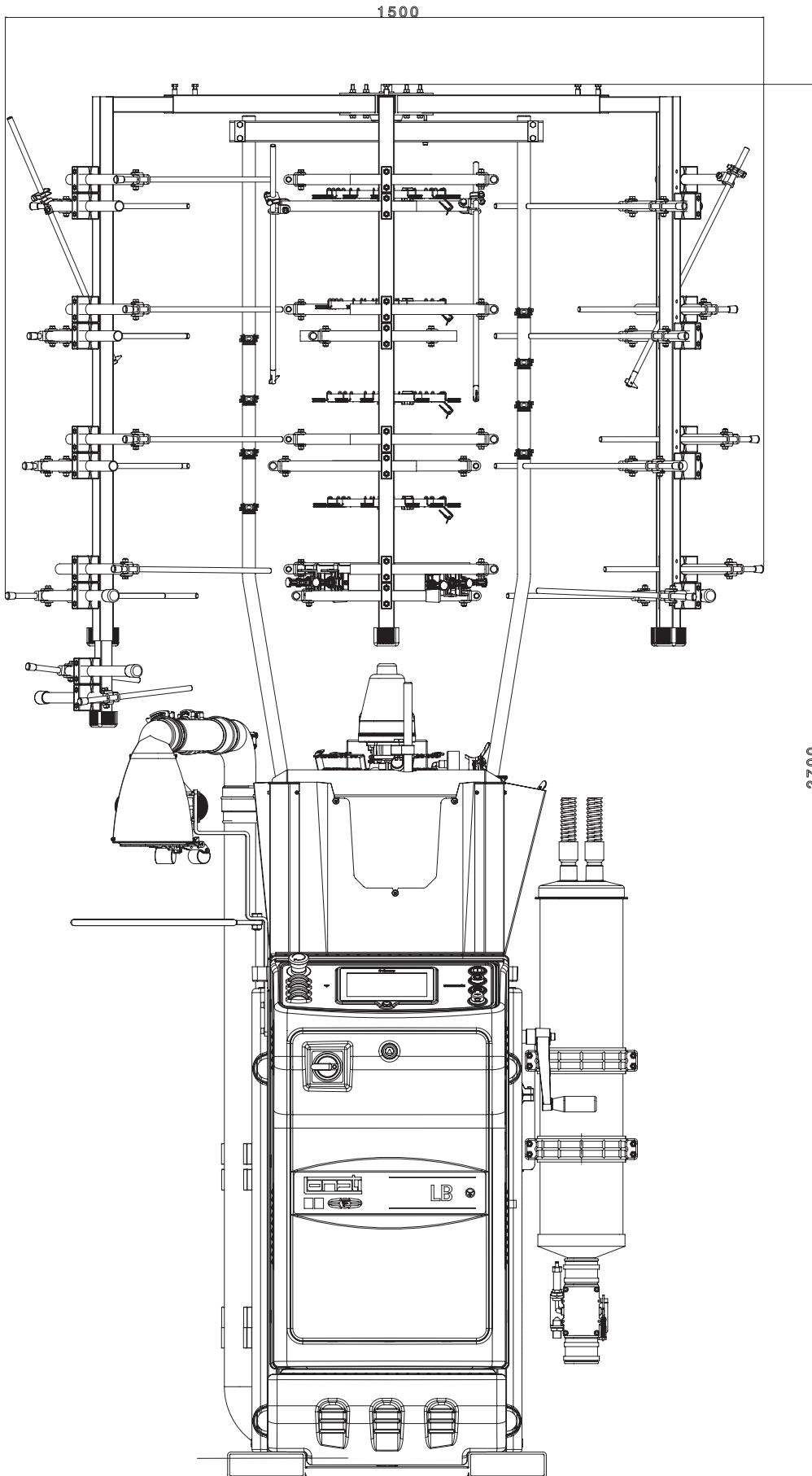

**FRONT VIEW**

Machine dimensions with 40 reels yarn creel

**NOTE:**

The picture may show fittings and equipment that are supplied on demand and not.

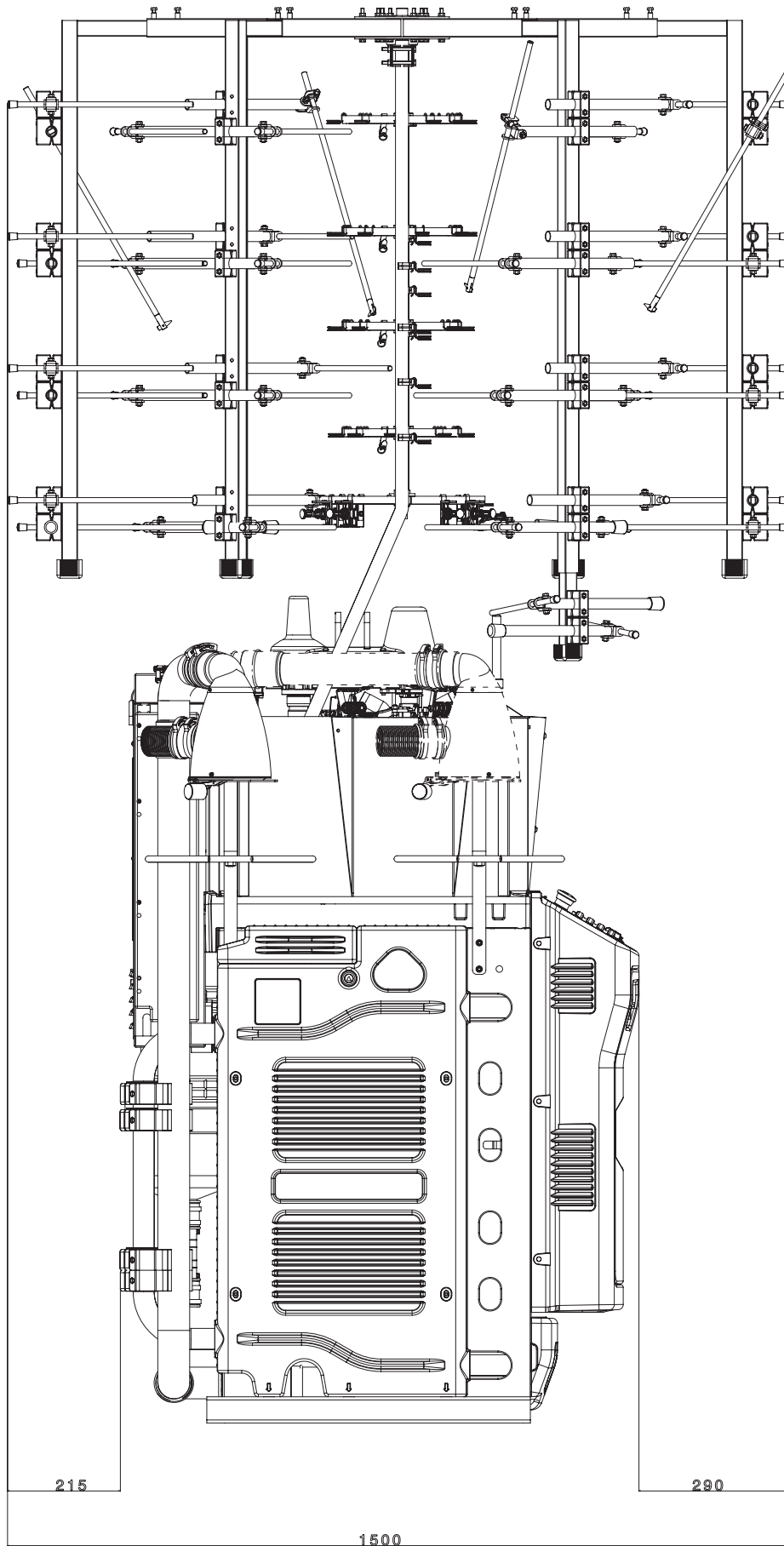

### SIDE VIEW

Machine dimensions with 40 reels yarn creel

### NOTE:

The picture may show fittings and equipment that are supplied on demand and not.







LONATI SPA  
Via Francesco Lonati, 3 | 25124 Brescia (Italy)  
Tel. +39 03023901 | Fax +39 030 2310024  
C.F.: 01469680175 | P.iva: 02096730961  
info@lonati.com - www.lonati.com