

GOAL
SINGLE CYLINDER
GK544F



SINGLE CYLINDER

GK544F

SBYS DEVICE
for automatic linking

KNITTING HEAD
designed to knit high quality
items and ensure constant
reliability over time.

**NEW
ELECTRONICS**
with high
resolution touch
screen display

NEW BASE
designed to increase solidity
and rigidity, allows a more
ergonomic assembling of
components

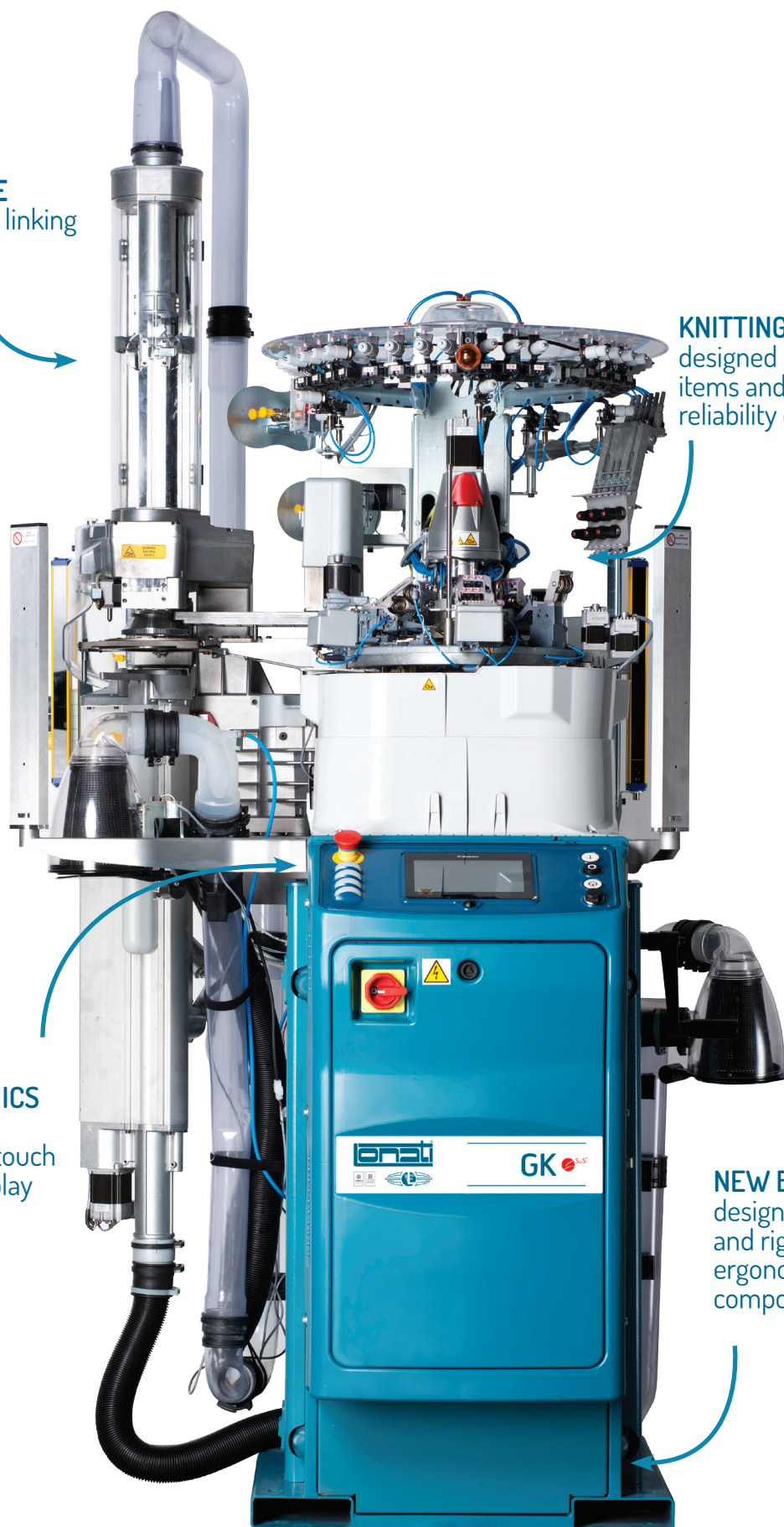

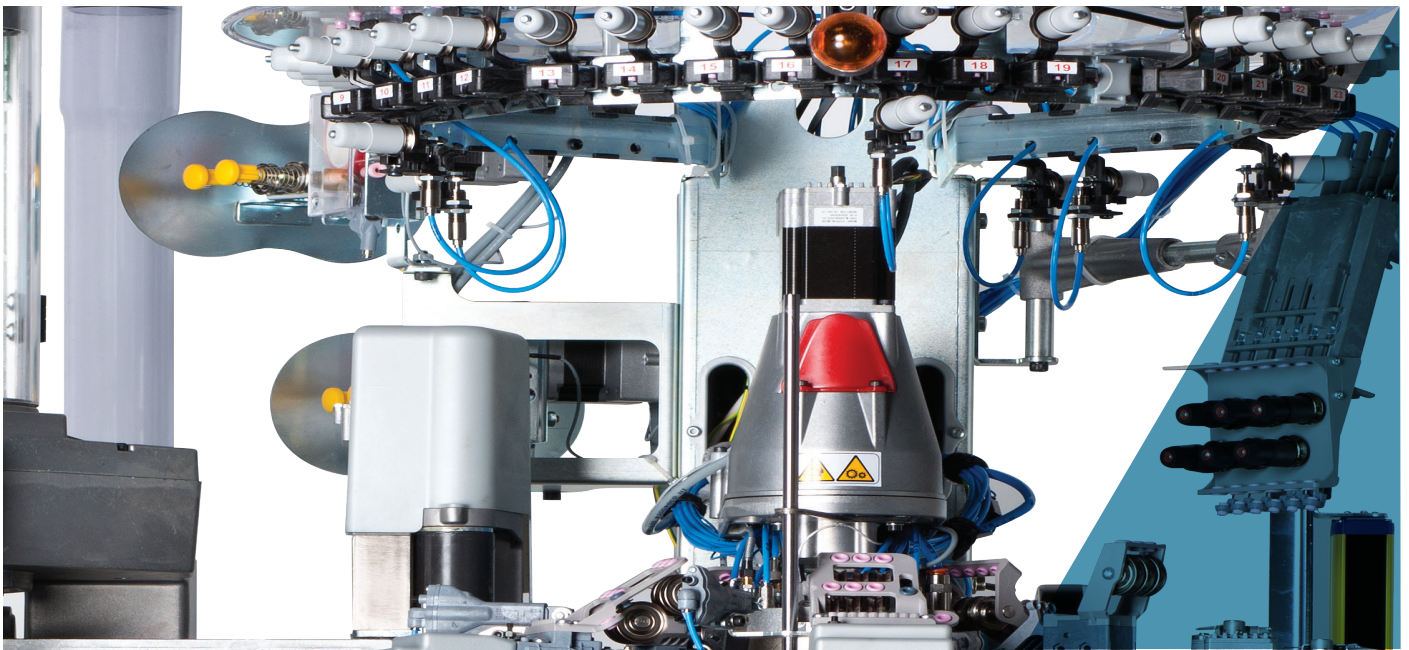

All images in this brochure are indicative and not binding.

SINGLE CYLINDER GK544F

Goal Series 4 feeds machines are designed to offer maximum productivity. They are available in 4" diameter with different numbers of needles. Automatic linking with SBYS device, performing a "real linking" technique. Advantages are remarkable: superior quality sock finishing, more comfort and resistance compared to socks made using conventional systems. Latest generation electronics provides control and execution of all machine commands. Drawings and articles are created and managed by Digraph 3 Plus software package, which contains a full collection of styles the operator can combine in different ways to obtain the desired results.

- 4 colors pattern on single feed course, plain knit or terry
- reciprocated heel and toe in different sizes
- 27 yarn fingers
- Rising dial and finger plate with stepping motor
- 9 electronic actuators for needle selection
- brushless coaxial main motor

MACHINE DIMENSIONS



Length max cm 127.3
Depth max cm 114.8
Height max cm 228

MACHINE WEIGHT



ca. 320 Kg

SINGLE CYLINDER

GK544F

TECHNICAL DATA

MODEL	CYLINDER DIAMETER	GAUGE	NEEDLE THICKNESS
GK544F	4"	from 8 1/2 to 13 1/2	0.85 - 0.70 mm

Above data are indicative and not binding.

STANDARD DEVICES

- Stepper motor electric dial with adjustable height
- Stitch cam feeds: 1,2,3,4 with three different heights.
- Motorized sinker cap for sinker pressure and angular position
- High resolution touch screen display
- Yarn sliding sensors guard cleaning device
- Heel yarn recover device with four positions
- 2 stepper motor controlled adjustable suction valves
- 9 yarn fingers on first feed, 6 on second, third, fourth feed
- Yarn creel
- USB port
- Circular yarn cutter with mechanical stop

MAIN OPTIONAL DEVICES

- LGL Eco Power or Eco Compact yarn storage feeder
- Dinema YoYo positive yarn feeders
- Elastic yarn positive feeders, for compression socks
- Dinema Plus elastane positive feeders
- Motorized stitch cams
- Antitwist device
- Footlet device
- Inside-out sock ejection device
- G-Flot device
- Recover yarn device, 6 positions
- Yarn trimming circular cutter with adjustable speed
- Linking device inspection lamp
- Dial with 5 pliers for bare or coated elastane
- Preparation for storage feeder "Unifeeder 2" by BTSR
- Ethernet board for connection to Dinema Nautilus data collector system
- Yarn sliding control sensors, Dinema ISPY
- 4 feeds for reinforced sole
- Pneumatic yarn tensioner for covered elastane
- Suction fan

POSSIBLE KNITTING

The standard machine can perform the following knittings

- 4 colors pattern plus ground color, tuck and float stitch, 1 feed, plain knit or terry
- 3 colors pattern plus ground color, mesh, tuck and float stitch, 1 feed, plain knit or terry
- With laid-in elastic: 3 colors pattern plus ground color, tuck and float stitch, 1 feed, plain knit or terry
- With laid-in elastic: 2 colors pattern plus ground color, tuck and float stitch, 1 feed, plain knit or terry
- Tuck and float stitch, jacquard, 4 feeds, plain knit or terry
- Elastic on 2 feeds, plain knit and terry
- Mesh on 2 feeds, plain knit and terry

SINGLE CYLINDER

GK544F

NUMBER OF COLORS

Number of colors

4 colors on course plus ground color, one feed

PERFORMANCES

	4" CYLINDER
KNITTING FEATURES	Patterns or selections 300rpm Plain knit without pattern, high speed sinker cap 350rpm
MAXIMUM SPEED	350 rpm

Above data are indicative and not binding.

DISCLAIMER: maximum speed may vary depending on yarn, knitting, lubrication etc

GAUGE

		GAUGE															
Model	ø	6½	7	7½	8	8½	9	9½	10	10½	11	11½	12	12½	13	13½	
						108 112		116 120		132		144		156		168	
GK544F	4"	Needle thickness 0.85 mm															
		Needle thickness 0.70 mm															

Above data are indicative and not binding.

DISCLAIMER:

All features in the brochure are for information only and subject to change without any prior notice.

For a complete list of available options, please contact Lonati sales network.

The Company accepts no liability for improper use of machinery.

SINGLE CYLINDER

GK544F

NOISE LEVEL (Maximum noise output for GK series models)

Noise pressure level on reference surface = LPA 79,5 dB - Noise power level = LWA 96,6 dB - Peak= 109,3 dB

LUBRICANTS

Average consumption for 100 dozens= 270 gr. Lonati recommends: Kluber Madol 183 Supreme - Fuchs Trax 16C

GREASE

For seals, bearings etc: Lonati recommends: TechnolubeSeals Damping grease Nyogel 774F-1

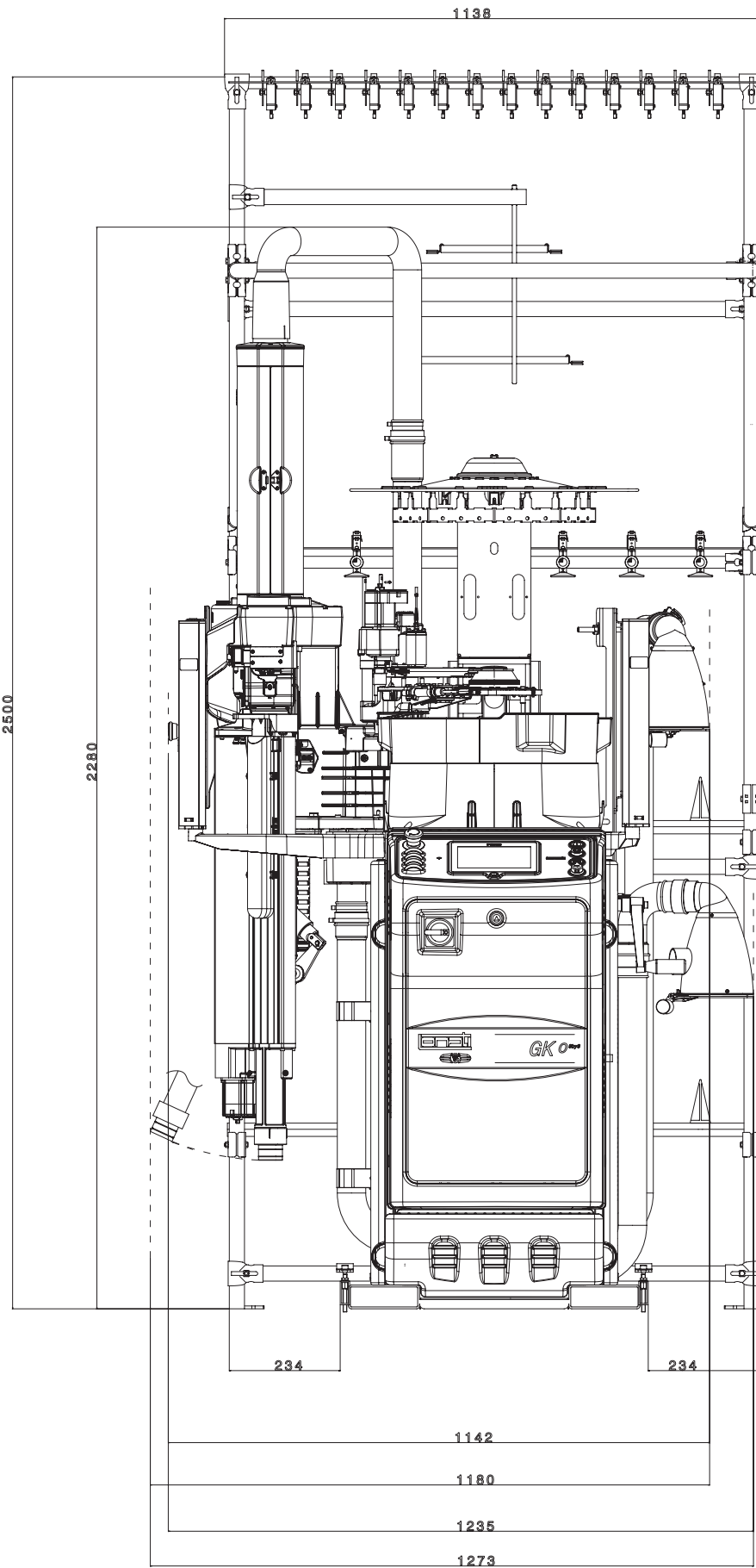

DESCRIPTION	CODE	NR. OF REELS	WEIGHT KG.	NOTES
Yarn creel	G3930061	28	51	Standard version
Yarn creel	G3930062	28	51	Version with BTR sensors

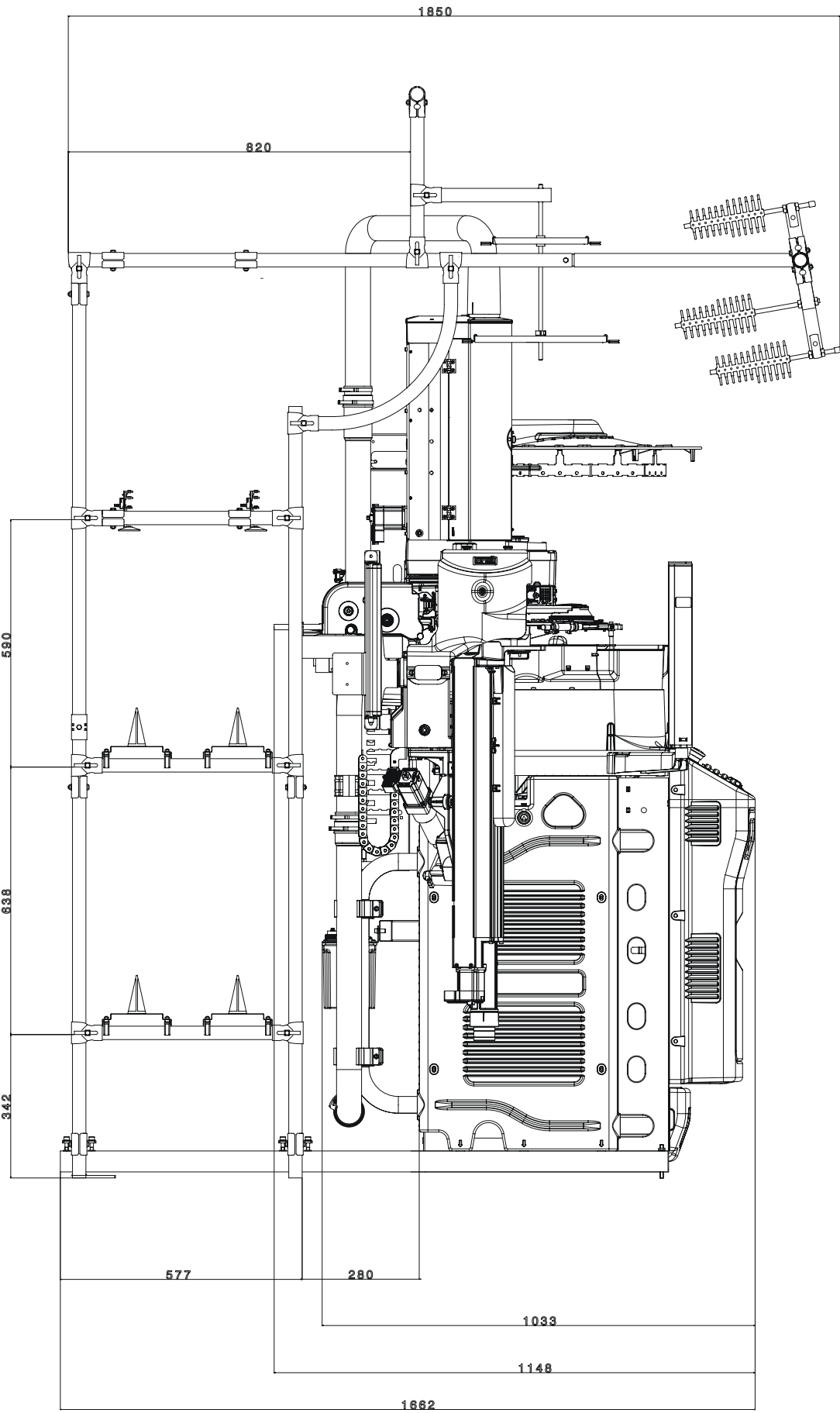

DESCRIPTION	CODE	NR. OF REELS	WEIGHT KG.	NOTES
Yarn creel	G3930061	28	51	Standard version
Yarn creel	G3930062	28	51	Version with BTR sensors





LONATI SPA

Via Francesco Lonati, 3 | 25124 Brescia (Italy)

Tel. +39 03023901 | Fax +39 030 2310024

C.F.: 01469680175 | P.iva: 02096730961

info@lonati.com - www.lonati.com